



BATH WASTE & OVERFLOW SCHEDULE 40 HALF KIT UNI-LIFT STOPPER WITH STANDARD TEST KIT TECHNICAL SPECIFICATION

Job Name _____	Item # _____
Location _____	
Engineer _____	Contractor _____
PO # _____	Tag _____
Representative _____	

SPECIFICATIONS

Dearborn Bath Waste & Overflow Schedule 40 Plastic Kits are manufactured to strict industry standards. Half Kit contains waste and overflow assemblies for Rough-In installation. Available in Schedule 40 ABS or PVC. Options include one or two hole face plate, brass or zinc die cast drain units, Condensate Elbow and variety of designer finishes.

DESCRIPTION

- Made of Schedule 40 Plastic
- Brass Drain Spud & Stopper
- One Hole Face Plate
- Meets ASME A112.18.2- 2005/CSA B125.2-2005

APPROVALS AND LISTINGS

IAPMO Listed

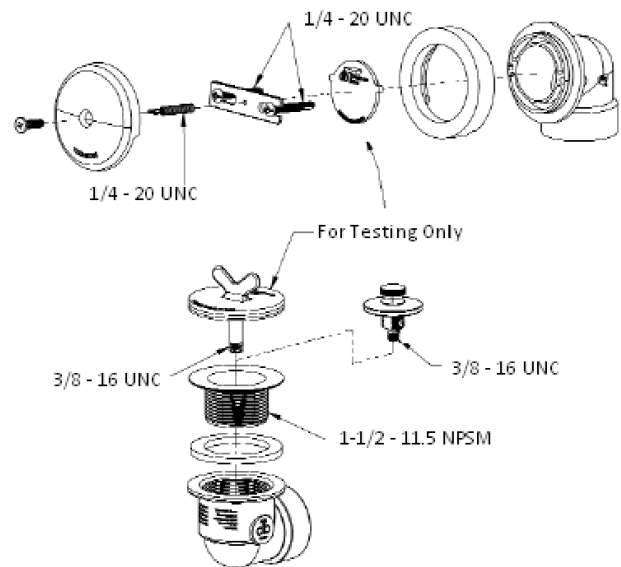

Access BIM/Revit content through www.oatey.com



BATH WASTE & OVERFLOW SCHEDULE 40 HALF KIT UNI-LIFT STOPPER WITH STANDARD TEST KIT TECHNICAL SPECIFICATION

PRODUCT SELECTOR

BATH WASTE & OVERFLOW SCHEDULE 40 HALF KIT UNI-LIFT STOPPER WITH STANDARD TEST KIT

✓	Product Number	Description	Carton Quantity	Carton Weight
	P7225B	Half Kit, Schedule 40 PVC Uni-Lift Stopper Mechanism – Chrome Finish Trim	20	35 lbs.
	P7225BAB	Half Kit, Schedule 40 PVC Uni-Lift Stopper Mechanism – Antique Bronze Finish Trim	20	35 lbs.
	P7225BBC	Half Kit, Schedule 40 PVC Uni-Lift Stopper Mechanism – Biscuit Finish Trim	20	35 lbs.
	P7225BBN	Half Kit, Schedule 40 PVC Uni-Lift Stopper Mechanism – Brushed Nickel Finish Trim	20	35 lbs.
	P7225BMB	Half Kit, Schedule 40 PVC Uni-Lift Stopper Mechanism – Matte Black Finish Trim	20	35 lbs.
	P7225BPB	Half Kit, Schedule 40 PVC Uni-Lift Stopper Mechanism – UltraShine Polished Brass Finish Trim	20	35 lbs.
	P7225BRB	Half Kit, Schedule 40 PVC Uni-Lift Stopper Mechanism – Rubbed Bronze Finish Trim	20	35 lbs.
	P7225BSC	Half Kit, Schedule 40 PVC Uni-Lift Stopper Mechanism – UltraShine Satin Chrome Finish Trim	20	35 lbs.
	P7225BSN	Half Kit, Schedule 40 PVC Uni-Lift Stopper Mechanism – UltraShine Satin Nickel Finish Trim	20	35 lbs.
	A7225B	Half Kit, Schedule 40 ABS Uni-Lift Stopper Mechanism – Chrome Finish Trim	20	25 lbs.
	A7225BMB	Half Kit Schedule 40 ABS Uni-Lift Stopper Mechanism – Matte Black Finish Trim	20	25 lbs.
	P9225BBG	Half Kit, Schedule 40 PVC Uni-Lift Stopper Mechanism with Zinc Drain Unit, 2 Hole Face Plate and No Test Kit – Chrome Finish Trim	25	31 lbs.
	A9225BBG	Half Kit, Schedule 40 ABS Uni-Lift Stopper Mechanism with Zinc Drain Unit, 2 Hole Face Plate and No Test Kit – Chrome Finish Trim	25	34 lbs.
	P7225BZ	Half Kit, Schedule 40 PVC Uni-Lift Stopper Mechanism with Zinc Drain Unit – Chrome Finish Trim	20	35 lbs.
	A7225BZ	Half Kit, Schedule 40 ABS Uni-Lift Stopper Mechanism with Zinc Drain Unit – Chrome Finish Trim	20	35 lbs.
	P7225BC	Half Kit, Schedule 40 PVC Uni-Lift Stopper Mechanism with Condensate Elbow – Chrome Finish Trim	20	35 lbs.
	A7225BC	Half Kit, Schedule 40 ABS Uni-Lift Stopper Mechanism with Condensate Elbow – Chrome Finish Trim	20	35 lbs.

Data is subject to manufacturing tolerances.

Access BIM/Revit content through www.oatey.com